



Instant Challenge Practice Set

This set of Instant Challenges is provided as a starter set for your teams to practice. Be sure to do as many Instant Challenges as possible as you prepare for the Tournament.

Instant Challenge Practice Set

Table of Contents

<i>Instant Challenge: Goals, Methods, Assessment</i>	3
How to Use these Practice Challenges	4
What is <i>Instant Challenge</i>?	4
Types of <i>Instant Challenges</i>	4
Practicing <i>Instant Challenges</i>	5
Ten Important Questions to ask after every <i>Instant Challenge</i> Activity	5
Tips for <i>Instant Challenge</i> Team Managers	6
<i>IC 1: Under the Bed</i>	7
<i>IC 2: Point of View</i>	10
<i>IC 3: A Choice of Sheets</i>	13
<i>IC 4: Lack of Connection</i>	15
<i>IC 5: Spelling Posts</i>	19
<i>IC 6: Multistructures</i>	24
<i>IC 7: Magnificent Monster</i>	28
<i>IC 8: Where Will It Take You</i>	31
<i>IC 9: Foot Puppets</i>	35
Create Your Own <i>ICs</i>	39

Teams and individuals using these Instant Challenges must hold a 2009-10 Team Number. The Destination ImagiNation® Team Number is a license to compete in sanctioned Tournaments and/or to use the Destination ImagiNation Team Challenges, Instant Challenges, Rules of the Road, and materials for educational purposes within your school or organization.

The contents of the 2009-10 Team Challenges, the Rules of the Road, and this set of Instant Challenges are copyrighted.

Instant Challenge: Goals, Methods, Assessment

Goals

- To put team’s creative problem solving abilities, creativity, and teamwork to the test in a short, time-driven Challenge.
- Develop creative problem solving abilities
- Develop performance techniques
- Develop improvisational skills
- Learn to analyze resources and use materials in new ways
- Improve time management skills
- Promote self-realization: Recognize and make the most of strengths
- Promote team-realization: Recognize and make the most of a team’s diverse strengths

Methods

- Teams will use provided materials to create a solution within the time limit and present the solution to Appraisers.
- Teams will analyze the Challenge and any available materials and determine how best to use them in the solution.
- Teams will use their collective and individual abilities and strengths to best advantage in solving the Challenge.
- Teams will keep track of time during the solution and presentation phases of the Challenge.

Assessment

- Each *Instant Challenge* includes a scoring system that is completed by Appraisers to give team feedback on their solution. Feedback can also be provided by Team Managers and other supporters during practice sessions.
- These Challenges are similar to Challenges used in Destination ImagiNation Tournaments and can be used to provide teams with “Tournament-like” conditions. Teams may choose to have an outside party, such as a Team Manager, evaluate their solutions in the categories within the Challenge. Feedback can and should be provided to the team when practicing with these Challenges.



How to Use these Practice Challenges

This set of *Instant Challenges* has been provided to help teams prepare for the *Instant Challenge* portion of their Tournament. Each Challenge is presented as it would appear at the Tournament.

For each Challenge, you will find:

- An Appraiser's Copy: This is the copy that is read to the team.
- A Team Copy: This copy should be placed where the team can read it as the Appraiser reads aloud.

In addition, some Challenges have additional pages:

- **Materials List:** In some Challenges, a set of materials would be on a table, and this list would be with the materials.
- **For Appraisers Only (not all Challenges):** For some Challenges, setup is required, and this page explains how the site should be set up.

What is *Instant Challenge*?

At your Tournament, your team will be scheduled to do an *Instant Challenge* in addition to your *Team Challenge*. *Instant Challenges* are confidential until the day of the Tournament, so your team will not know anything about the specific *Instant Challenge* you will be asked to solve until you are escorted to your *Instant Challenge* competition room.

The *Instant Challenge* portion of the competition is usually between five and ten minutes in duration, and is worth a total possible score of 100 points. Although each *Instant Challenge* has different requirements, all *Instant Challenges* reward teams for teamwork and the uniqueness and creativity of the team's solution.

Types of *Instant Challenges*

Instant Challenges can be loosely divided into two types, Performance-Based and Task-Based. However, many *Instant Challenges* are a blend of these two basic types. You will not know which type of *Instant Challenge* your team will receive until you enter the competition room.

1. **Performance-Based:** The focus of a Performance-Based *Instant Challenge* is on your team working together to create and perform a theatrically-oriented solution for the Appraisers. In this type of Challenge you will be scored on the creativity of your performance, your presentation, and/or use of materials, along with teamwork. Your team may be asked to use words, language, conversation, and/or dramatic characterizations to solve the Challenge, or the solution may be non-verbal. Teams may be given real or imaginary materials to use for their solutions. Teams may or may not be given time to practice their solutions before presenting to the Appraisers.
2. **Task-Based:** The focus of a Task-Based *Instant Challenge* is on your team working together to move, build, change, or protect materials they are given in order to complete a task. Your team may also be asked to communicate information. Teams will be scored on how well they work together to design the solution, on the creativity of their final project, and on their success in completing the task. Team members may or may not be allowed to talk during the Challenge.

Additional IC Resources

- Be sure to read the sections on *Instant Challenge* in the *Rules of the Road*.
- Books and CDs of collected *Instant Challenges* are available www.ShopDI.org.

Practicing *Instant Challenges*

After each *Instant Challenge*: Debrief!

ALWAYS be sure to Debrief at the end of each *Instant Challenge* or set of ICs. Keep your questions friendly and not judgmental (defer judgment). Allow the TEAM to answer the questions and draw their own conclusions.

Ten Important Questions to ask after every *Instant Challenge* Activity:

1. How do you think you did as a team? What did you learn about teamwork by doing this Challenge?
2. How well did you manage your time? How might you have used your time more effectively?
3. What were some strengths of your solution? What worked well?
4. If you were to start the Challenge over again, what might you do differently?
5. Did your team use any CPS tools? If so, which ones? If not, which ones might you have used?
6. How well do you feel you utilized the materials you were given? How might you have used the materials differently? Were there materials you did NOT use? If not, why not? How might they have been used?
7. How well did you create your solution to fit the emphasis in the scoring? Would you do anything differently?
8. If the solution did not work, what could you have done to make the solution work?
9. Could your solution have been more creative, novel, or unique? What might you have done to make that happen?
10. Finally, most important: WHAT DID YOU LEARN?

Tips for *Instant Challenge* Team Managers

There are many different things you can do to help your team improve their *Instant Challenge* skills. Some ideas you might try are listed below.

1. Ask the team to generate ideas about which team jobs they might assign themselves so they can be better organized in their approach to *Instant Challenges*. Some of these jobs might be:
 - Timekeeper: makes the team aware of the time left for them to work on their Challenge
 - Scorer: makes sure the team is mindful of what is important in the Challenge scoring
 - Story: helps to organize the performance, if one is required
 - Technical: helps to organize the technical element, if one is required
2. Have the team members switch jobs for each practice session so they become familiar with all of them.
3. Videotape the team as they practice *Instant Challenge*. Then, as the tape is replayed, have the team critique what they see. This is especially valuable for developing teamwork skills.
4. In order to encourage fluidity and to discourage the team from thinking there is only one “correct” solution to a Challenge, have them do the same *Instant Challenge* several times, each time requiring a different solution.
5. Have them do the same Task-Based Challenge several times and remove an important material each time they do it.
6. When they have completed an *Instant Challenge*, don’t retire it permanently. Have the team do it again several weeks later. Discuss with the team whether they are approaching the Challenge differently than they did before; if it is different have them discuss what they had learned that made them change their approach.

APPRAISER COPY

Destination ImagiNation Instant Challenge

Entry Level

UNDER THE BED

Challenge:

Your team is to present a PERFORMANCE about something under the bed.

Time:

You will have up to 4 minutes to use your IMAGINATION to plan and practice your skit and then up to 2 minutes to present your PERFORMANCE to the Appraisers.

The Scene:

There are scary things under the bed at night. Sometimes they are not as scary as you think; sometimes they are worse. You are to present a skit about something under the bed. Your skit should include a surprise. You should write down the surprise on the sheet the Appraisers will give you, and hand it back to the Appraisers at the end of the PERFORMANCE.

Materials:

All materials are imaginary. A piece of paper and 2 pencils will be available for your team to use as you plan and present your PERFORMANCE.

Scoring: You will receive

- A. 10 points for including a surprise in your skit.
- B. Up to 20 points for how creatively you show what is under the bed.
- C. Up to 20 points for the creativity of the surprise.
- D. Up to 30 points for the creativity of your PERFORMANCE.
- E. Up to 20 points for how well your team works together.

For Appraisers Only:

1. The setup consists of a bed in the middle of the room. If an actual bed is not available, a taped area can be used to represent a bed.

TEAM COPY

Destination ImagiNation Instant Challenge

Entry Level

UNDER THE BED

Challenge:

Your team is to present a PERFORMANCE about something under the bed.

Time:

You will have up to 4 minutes to use your IMAGINATION to plan and practice your skit and then up to 2 minutes to present your PERFORMANCE to the Appraisers.

The Scene:

There are scary things under the bed at night. Sometimes they are not as scary as you think; sometimes they are worse. You are to present a skit about something under the bed. Your skit should include a surprise. You should write down the surprise on the sheet the Appraisers will give you, and hand it back to the Appraisers at the end of the PERFORMANCE.

Materials:

All materials are imaginary. A piece of paper and 2 pencils will be available for your team to use as you plan and present your PERFORMANCE.

Scoring: You will receive

- A. 10 points for including a surprise in your skit.
- B. Up to 20 points for how creatively you show what is under the bed.
- C. Up to 20 points for the creativity of the surprise.
- D. Up to 30 points for the creativity of your PERFORMANCE.
- E. Up to 20 points for how well your team works together.

APPRAISER COPY

Destination ImagiNation Instant Challenge

Advanced Level

POINT OF VIEW

Challenge:

Your team is to present a PERFORMANCE in which 2 totally different interpretations are given of 3 different events or facts.

Time:

You will have up to 5 minutes to use your IMAGINATION to plan and practice your skit and then up to 2 minutes to present your PERFORMANCE .

The Scene:

Sometimes people have totally different interpretations of the same event or facts. For example, if there is a cup partially filled with water, one group may say the cup is half full, and the other that the cup is half empty.

- **Part One (5 minutes):** You are to think of 3 events or facts that can each be interpreted 2 totally different ways and then present a PERFORMANCE in which you present the different interpretations of each of the events or facts. You should write down the 3 events or facts that you have chosen on the sheets the Appraisers will give you and hand one of the sheets back to the Appraisers at the end of Part One.
- **Part Two (2 minutes):** Present your PERFORMANCE.

Materials:

All materials are imaginary. A piece of paper and a pencil will be available for your team to use as you plan and present your PERFORMANCE.

Scoring: You will receive up to

- A. 10 points (60 points maximum) for the creativity of each of the 2 different interpretations of each of the 3 events or facts.
- B. 20 points for the creativity of your PERFORMANCE.
- C. 20 points for how well your team works together.

TEAM COPY

Destination ImagiNation Instant Challenge

Advanced Level

POINT OF VIEW

Challenge:

Your team is to present a PERFORMANCE in which 2 totally different interpretations are given of 3 different events or facts.

Time:

You will have up to 5 minutes to use your IMAGINATION to plan and practice your skit and then up to 2 minutes to present your PERFORMANCE .

The Scene:

Sometimes people have totally different interpretations of the same event or facts. For example, if there is a cup partially filled with water, one group may say the cup is half full, and the other that the cup is half empty.

Part One (5 minutes):

- You are to think of 3 events or facts that can each be interpreted 2 totally different ways and then present a PERFORMANCE in which you present the different interpretations of each of the events or facts.
- You should write down the 3 events or facts that you have chosen on the sheets the Appraisers will give you and hand one of the sheets back to the Appraisers at the end of Part One.

Part Two (2 minutes):

- Present your PERFORMANCE.

Materials:

All materials are imaginary. A piece of paper and a pencil will be available for your team to use as you plan and present your PERFORMANCE.

Scoring: You will receive up to

- A. 10 points (60 points maximum) for the creativity of each of the 2 different interpretations of each of the 3 events or facts.
- B. 20 points for the creativity of your PERFORMANCE.
- C. 20 points for how well your team works together.

Events Or Facts To Be Interpreted

1. _____

2. _____

3. _____

APPRAISER COPY

Destination ImagiNation *Instant Challenge*

Entry and Advanced Levels

A CHOICE OF SHEETS

Challenge: Create a mystery story and then present a PERFORMANCE in which a sheet is your only prop. For the purpose of this Challenge, a “mystery” is something you don’t understand that you need to use clues to solve.

Time: You will have up to 5 minutes to use your IMAGINATION to create your mystery story, as well as to plan and practice your PERFORMANCE, and then up to 2 minutes to present your PERFORMANCE to the Appraisers.

The Scene: Everyone loves a good mystery! Create a skit involving a mystery where:

1. There is a mystery that needs to be solved.
2. There is at least one unusual character.
3. There are one or more clues.
4. There is a solution to the mystery.

When you present your skit, your only prop will be a sheet. Try to use the sheet in as many ways as possible.

Materials: You will be given three different sheets from which to choose. However, you may only use one sheet in your PERFORMANCE and this sheet may not be damaged. A piece of paper and a pencil also will be available for your team to use as you plan and present your PERFORMANCE.

Scoring: You will receive

- A. 5 points each (20 points maximum) if your PERFORMANCE includes a mystery that needs to be solved, an unusual character, at least one clue and a solution to the mystery.
- B. Up to 30 points for how creatively you use the sheet in your PERFORMANCE.
- C. Up to 30 points for the creativity of your PERFORMANCE.
- D. Up to 20 points for how well your team works together.

FOR APPRAISERS ONLY:

1. The team should be given 3 colored sheets from which to chose.
(Sheets can be of different sizes and have patterns, but no white sheets.)

TEAM COPY

Destination ImagiNation Instant Challenge

Entry and Advanced Levels

A CHOICE OF SHEETS

Challenge: Create a mystery story and then present a PERFORMANCE in which a sheet is your only prop. For the purpose of this Challenge, a “mystery” is something you don’t understand that you need to use clues to solve.

Time: You will have up to 5 minutes to use your IMAGINATION to create your mystery story, as well as to plan and practice your PERFORMANCE, and then up to 2 minutes to present your PERFORMANCE to the Appraisers.

The Scene: Everyone loves a good mystery! Create a skit involving a mystery where:

1. There is a mystery that needs to be solved.
2. There is at least one unusual character.
3. There are one or more clues.
4. There is a solution to the mystery.

When you present your skit, your only prop will be a sheet. Try to use the sheet in as many ways as possible.

Materials: You will be given 3 different sheets from which to choose. However, you may only use one sheet in your PERFORMANCE and this sheet may not be damaged. A piece of paper and a pencil also will be available for your team to use as you plan and present your PERFORMANCE.

Scoring: You will receive

- A. 5 points each (20 points maximum) if your PERFORMANCE includes a mystery that needs to be solved, an unusual character, at least one clue and a solution to the mystery.
- B. Up to 30 points for how creatively you use the sheet in your PERFORMANCE.
- C. Up to 30 points for the creativity of your PERFORMANCE.
- D. Up to 20 points for how well your team works together.

APPRAISER COPY

Destination ImagiNation *Instant Challenge*

Entry Level

LACK OF CONNECTION

Challenge: Your TASK is to create a bridge that holds weight using the fewest materials possible.

Time: You will have up to 5 minutes to use your IMAGINATION to design, build and test a bridge and up to 1 minute to place weight on the bridge for score.

Setup: In the center of the room are 2 tables with a gap between them. On the other side of the room is a table with materials.

Procedure:

- **Part One (5 minutes):** Use the materials on the table to build a bridge that spans the gap between the 2 tables. The bridge may NOT be attached to the table and may only rest on top of the table. There are 8 types of materials on the table. You will receive extra score for not using all the different types of materials.
- **Part Two (1 minute):** Place weight on the bridge for score. At the end of Part Two, you will receive additional score for each weight successfully supported by your bridge.

Materials:

- 12in (30.48cm) of String
- 4 Craft Sticks
- 1 Sheet of Newspaper
- 1 Can of Soup
- 1 Piece of Paper
- 1 Paper Clip
- 1 Chenille Stick (Pipe Cleaner)
- 1 Ruler

The ruler and the can of soup may NOT be damaged.

Scoring: You will receive

- 10 points (40 points maximum) for each type of material that your team does NOT use.
- 5 points (20 points maximum) for each weight that your bridge successfully holds at the end of Part Two.
- Up to 20 points for how creatively you use the materials.
- Up to 20 points for how well your team works together.

For Appraisers Only:

1. The setup consists of 2 tables in the center of the room, placed 2ft (60.96cm) apart. There is also a 2nd table with materials and 4 weights.

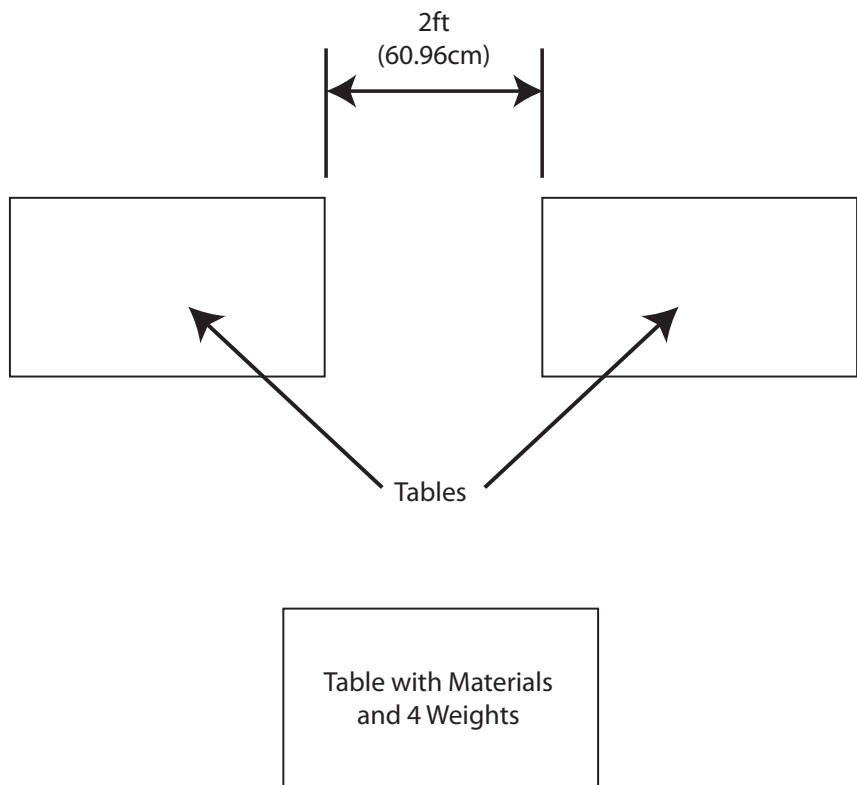

2. The weights consist of two 6in (15.24cm) nails connected by a rubber band.

TEAM COPY

Destination ImagiNation Instant Challenge

Entry Level

LACK OF CONNECTION

Challenge:

Your TASK is to create a bridge that holds weight using the fewest materials possible.

Time:

You will have up to 5 minutes to use your IMAGINATION to design, build and test a bridge and up to 1 minute to place weight on the bridge for score.

Setup: In the center of the room are 2 tables with a gap between them. On the other side of the room is a table with materials.

Procedure: Part One (5 minutes):

- Use the materials on the table to build a bridge that spans the gap between the 2 tables.
- The bridge may NOT be attached to the table and may only rest on top of the table.
- There are 8 types of materials on the table.
- You will receive extra score for not using all the different types of materials.

Part Two (1 minute):

- Place weight on the bridge for score.
- At the end of Part Two, you will receive additional score for each weight successfully supported by your bridge.

Scoring: You will receive

- A. 10 points (40 points maximum) for each type of material that your team does NOT use.
- B. 5 points (20 points maximum) for each weight that your bridge successfully holds at the end of Part Two.
- C. Up to 20 points for how creatively you use the materials.
- D. Up to 20 points for how well your team works together.

LACK OF CONNECTION

Materials: **(Tape to Table)**

- 12in (30.96cm) of String
- 1 Piece of Paper
- 4 Craft Sticks
- 1 Paper Clip
- 1 Sheet of Newspaper
- 1 Chenille Stick (Pipe Cleaner)
- 1 Can of Soup
- 1 Ruler

The ruler and the can of soup may NOT be damaged.

APPRAISER COPY

Destination ImagiNation *Instant Challenge*

Advanced Level

SPELLING POSTS

Challenge:

Your TASK is to move posts to spell as many different 4-letter English words as possible.

Time:

You will have up to 2 minutes to use your IMAGINATION to divide your team into 2 groups and discuss strategy and then up to 5 minutes to create 4-letter English words by moving posts.

Setup:

In the center of the room are 4 taped squares. Within each square is a wooden post with a letter on the top of each of the 4 sides. There are also 2 additional taped lines on either side of the taped squares.

Procedure:

- **Part One (2 minutes):** Divide your team into 2 groups. At the end of Part One, each group will go behind one of the taped lines. You should also discuss strategy during Part One. Your teammates will be taking turns moving one of the posts $\frac{1}{4}$ turn in order to spell 4-letter English words. You will be given sheets that show the letters on each post, as seen from each of the sides.
- **Part Two (5 minutes):** Team members will take turns going into the area between the taped lines and moving 1 of the posts a $\frac{1}{4}$ turn to change the letters facing the 2 groups of team members. If moving this post results in a 4-letter English word appearing from left to right on either side of the posts, a team member should say that word in order for the team to receive score. Once a team member has left the area between the taped lines, a team member from the opposite side can cross into the center area and turn one of the posts a $\frac{1}{4}$ turn. The object is to keep turning posts in this fashion to create as many different 4-letter English words as possible. Additional score will be given if turning a post creates 4-letter words on both sides of the posts at the same time.

Materials:

Each side will be given a piece of paper and a pencil.

Scoring: You will receive

- A. 3 points (60 points maximum) for each different 4-letter English words spelled in Part Two.
- B. 10 points (20 points maximum) for each time two 4-letter English words are spelled at the same time on each side of the posts.
- C. Up to 20 points for how well your team works together.

For Appraisers Only:

1. The setup consists of four 12in x 12in (30.48cm x 30.48cm) taped squares in the center of the room. Within each taped square is a 4in x 4in x 12in (10.16cm x 10.16cm x 30.48cm) wooden post with letters attached to the top of each side. There are additional taped lines 5ft (152.40cm) on either side of the taped squares.

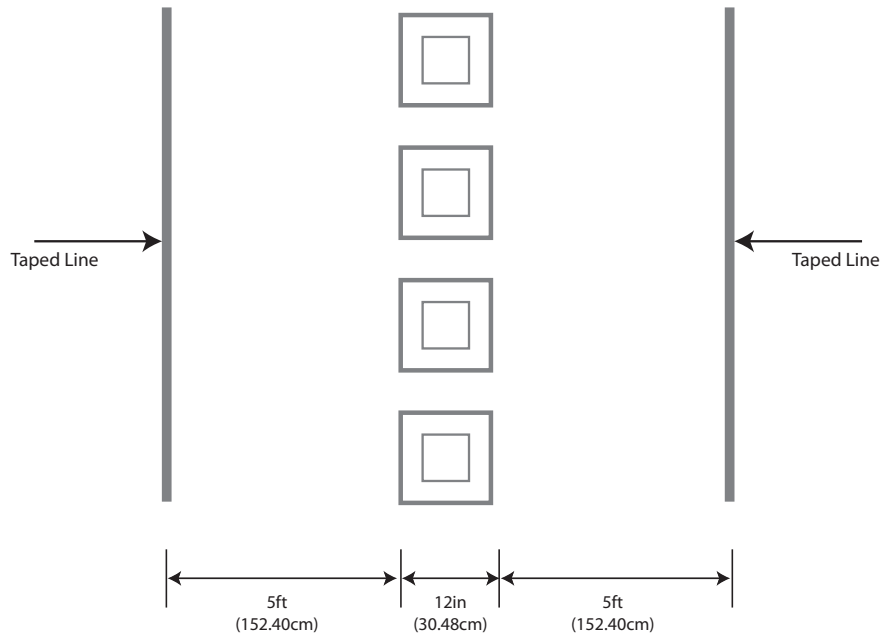

2. The posts need to be put back in the same positions for each team.

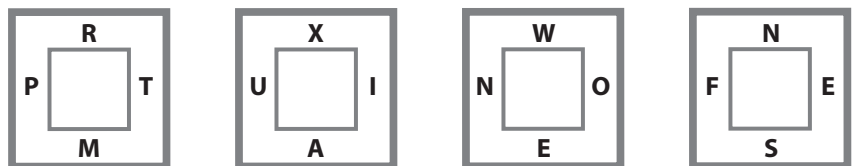

TEAM COPY

Destination ImagiNation *Instant Challenge*

Advanced Level

SPELLING POSTS

Challenge: Your TASK is to move posts to spell as many different 4-letter English words as possible.

Time: You will have up to 2 minutes to use your IMAGINATION to divide your team into 2 groups and discuss strategy and then up to 5 minutes to create 4-letter English words by moving posts.

Setup: In the center of the room are 4 taped squares. Within each square is a wooden post with a letter on the top of each of the 4 sides. There are also 2 additional taped lines on either side of the taped squares.

Procedure:

Part One (2 minutes):

- Divide your team into 2 groups.
- At the end of Part One, each group will go behind one of the taped lines.
- You should also discuss strategy during Part One.
- Your teammates will be taking turns moving one of the posts $\frac{1}{4}$ turn in order to spell 4-letter English words.
- You will be given sheets that show the letters on each post, as seen from each of the sides.

Part Two (5 minutes):

- Team members will take turns going into the area between the taped lines and moving 1 of the posts a $\frac{1}{4}$ turn to change the letters facing the 2 groups of team members.
- If moving this post results in a 4-letter English word appearing from left to right on either side of the posts, a team member should say that word in order for the team to receive score.
- Once a team member has left the area between the taped lines, a team member from the opposite side can cross into the center area and turn one of the posts a $\frac{1}{4}$ turn.
- The object is to keep turning posts in this fashion to create as many different 4-letter English words as possible.
- Additional score will be given if turning a post creates 4-letter words on both sides of the posts at the same time.

Materials:

Each side will be given a piece of paper and a pencil.

Scoring: You will receive

- A. 3 points (60 points maximum) for each different 4-letter English words spelled in Part Two.
- B. 10 points (20 points maximum) for each time two 4-letter English words are spelled at the same time on each side of the posts.
- C. Up to 20 points for how well your team works together.

LETTERS ON POSTS

SIDE ONE

M	A	E	S
P	U	N	F
R	X	W	N
T	I	O	E

LETTERS ON POSTS

SIDE TWO

N	W	X	R
E	O	I	T
S	E	A	M
F	N	U	P

APPRAISER COPY

Destination ImagiNation *Instant Challenge*

Entry and Advanced Levels

MULTISTRUCTURES

Challenge:

Your TASK is to build a free-standing structure for each team member that is as high as possible. For the purpose of this Challenge, “free-standing” means that the structure is not attached to anything.

Time:

You will have up to 1 minute to use your IMAGINATION to discuss strategy and then up to 3 minutes to build the towers.

Setup:

In the middle of the room are 2 tables. On top of the tables are 7 taped squares. Next to each taped square is a set of materials.

Procedure:

- **Part One (1 minute):** Discuss strategy. During this part of the Challenge, you may NOT touch any of the materials.
- **Part Two (3 minutes):** Using only the materials next to each taped square, build a free-standing structure that is as high as possible for each team member within the taped square. Team members may help each other build. At the end of Part Two, the Appraisers will measure the heights of the 2 tallest structures.

Materials:

- 4 Straws
- 6 Paper Clips
- 1 Mailing Label
- 4 Index Cards
- 1 Craft Stick
- 2 Rubber Bands

In addition, your team will have a yardstick (meterstick) to use, but this may NOT be damaged and may NOT be part of a structure.

Scoring: You will receive

- 20 points if there is a free-standing structure for each team member within a taped square at the end of Part Two.
- 1 point (40 points maximum) for each inch (2.54cm) of height in the 2 tallest structures at the end of Part Two.
- Up to 20 points for how creatively you use the materials.
- Up to 20 points for how well your team works together.

For Appraisers only:

1. The setup consists of 2 tables in the middle of the room. There are seven 6in x 6in (15.24cm x 15.24cm) taped squares on the table. Next to each taped square is a set of materials. There is also a yardstick (meterstick) on the table.

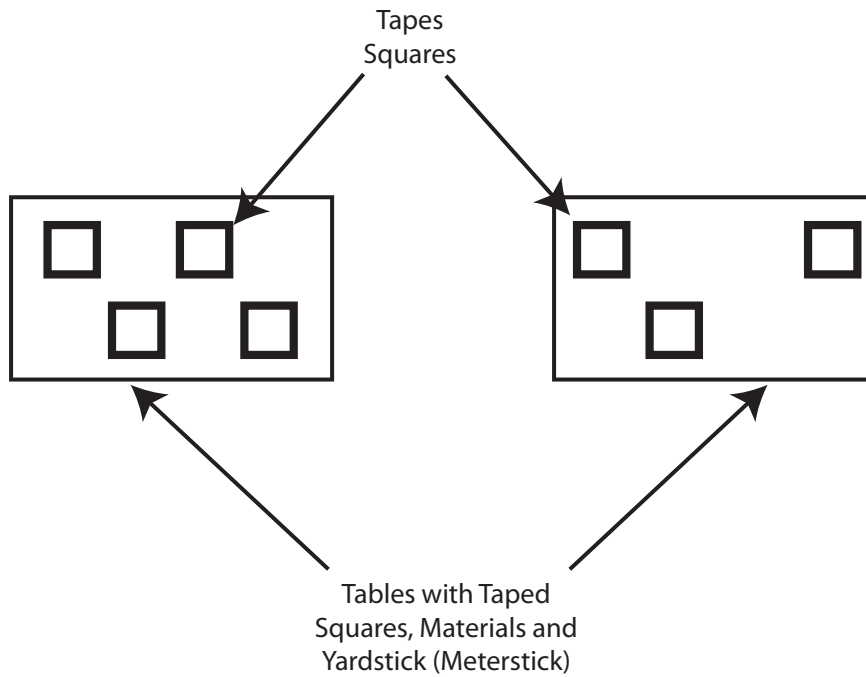

TEAM COPY

Destination ImagiNation *Instant Challenge*

Entry and Advanced Levels

MULTISTRUCTURES

Challenge:

Your TASK is to build a free-standing structure for each team member that is as high as possible. For the purpose of this Challenge, “free-standing” means that the structure is not attached to anything.

Time:

You will have up to 1 minute to use your IMAGINATION to discuss strategy and then up to 3 minutes to build the towers.

Setup:

In the middle of the room are 2 tables. On top of the tables are 7 taped squares. Next to each taped square is a set of materials.

Procedure:

- **Part One (1 minute):** Discuss strategy. During this part of the Challenge, you may NOT touch any of the materials.
- **Part Two (3 minutes):** Using only the materials next to each taped square, build a free-standing structure that is as high as possible for each team member within the taped square. Team members may help each other build. At the end of Part Two, the Appraisers will measure the heights of the 2 tallest structures.

Scoring: You will receive

- A. 20 points if there is a free-standing structure for each team member within a taped square at the end of Part Two.
- B. 1 point (40 points maximum) for each inch (2.54cm) of height in the 2 tallest structures at the end of Part Two.
- C. Up to 20 points for how creatively you use the materials.
- D. Up to 20 points for how well your team works together.

MULTISTRUCTURES

Materials:

(Tape to Table)

- 4 Straws
- 6 Paper Clips
- 2 Rubber Bands
- 1 Craft Stick
- 1 Mailing Label
- 4 Index Cards

In addition, your team will have a yardstick (meterstick) to use, but this may NOT be damaged and may NOT be part of a structure.

APPRAISER COPY

Destination ImagiNation *Instant Challenge*

Entry Level

MAGNIFICENT MONSTER

Challenge: Your TASK is to create a monster and then to present a PERFORMANCE in which you show the special talents of your monster.

Time: You will have up to 5 minutes to use your IMAGINATION to make your monster and plan your skit and then up to 2 minutes to present your PERFORMANCE.

The Scene: Some scary creatures have talents beyond hiding under the bed! Your team will create a monster out of the materials provided and then present a PERFORMANCE in which you explain the special talents of your monster.

- **Part One (5 minutes):** Use the materials on the table to create your monster and plan your skit.
- **Part Two (2 minutes):** Present a PERFORMANCE in which you show the special talents of your monster. You should make sure to include the monster in your PERFORMANCE.

Materials:

- 6 Paper Clips
- 2 Paper Cups
- 3 Styrofoam Balls
- 3 Pieces of Paper
- 6 Mailing Labels
- 10 Chenille Sticks (Pipe Cleaners)
- 10 Straws
- 1 Plastic Bag

A box of markers and a pair of scissors will be available for your team to use, but they may NOT be part of your monster. In addition, your team will have a piece of paper and a pencil to use as you plan and present your PERFORMANCE.

Scoring: You will receive

- A. Up to 30 points for the creativity of your monster.
- B. Up to 20 points for the creativity of your monster's special talents.
- C. Up to 30 points for the creativity of your PERFORMANCE.
- D. Up to 20 points for how well your team works together.

APPRAISER COPY

Destination ImagiNation *Instant Challenge*

Entry Level

MAGNIFICENT MONSTER

Challenge: Your TASK is to create a monster and then to present a PERFORMANCE in which you show the special talents of your monster.

Time: You will have up to 5 minutes to use your IMAGINATION to make your monster and plan your skit, and then up to 2 minutes to present your PERFORMANCE.

The Scene: Some scary creatures have talents beyond hiding under the bed! Your team will create a monster out of the materials provided and then present a PERFORMANCE in which you explain the special talents of your monster.

- Part One (5 minutes): Use the materials on the table to create your monster and plan your skit.
- Part Two (2 minutes): Present a PERFORMANCE in which you show the special talents of your monster. You should make sure to include the monster in your PERFORMANCE.

Scoring: You will receive

- Up to 30 points for the creativity of your monster.
- Up to 20 points for the creativity of your monster's special talents.
- Up to 30 points for the creativity of your PERFORMANCE.
- Up to 20 points for how well your team works together.

MAGNIFICENT MONSTER

Materials:
(Tape to Table)

- 6 Paper Clips
- 3 Pieces of Paper
- 10 Straws
- 2 Paper Cups
- 6 Mailing Labels
- 1 Plastic Bag
- 3 Styrofoam Balls
- 10 Chenille Sticks (Pipe Cleaners)

A box of markers and a pair of scissors will be available for your team to use, but may NOT be part of your monster. In addition, your team will have a piece of paper and a pencil to use as you plan and present your PERFORMANCE.

APPRAISER COPY

Destination ImagiNation *Instant Challenge*

Advanced Level

Where Will It Take You?

Challenge: Your TASK is to build and test a vehicle that will travel as far as possible and then to present a PERFORMANCE in which you show where the vehicle will take you.

Time: You will have up to 4 minutes to use your IMAGINATION to build and test your vehicle, as well as plan your skit, and up to 2 minutes to test your vehicle for score and to present your PERFORMANCE to the Appraisers.

Setup: In the center of the room is the “test area.” On one side of the test area is a taped line. There is also a table with materials.

- **Part One (4 minutes):** Use the materials on the table to build a vehicle that will travel as far as possible. You may also test your vehicle, as well as plan your skit, in Part One.
- **Part Two (2 minute):** Move your vehicle for score and present a PERFORMANCE in which you show where the vehicle will take you. Your vehicle should start behind the taped line and travel as far as possible without being touched beyond the taped line. Your vehicle may NOT be thrown. Once your vehicle has stopped, you may retrieve it for another try. You may make as many tries as you want during Part Two. The longest trip will receive score.

Materials:

- | | | |
|--|---|--|
| <input type="checkbox"/> 2 Cardboard Tubes | <input type="checkbox"/> 2 Rubber Bands | <input type="checkbox"/> 1 Pencil |
| <input type="checkbox"/> 2 Paper Bags | <input type="checkbox"/> 2 Plastic Spoons | <input type="checkbox"/> 6 Paper Clips |
| <input type="checkbox"/> 4 Straws | <input type="checkbox"/> 1 Piece of Heavy Paper | |
| <input type="checkbox"/> 3 Plastic Lids | <input type="checkbox"/> 2 Mailing Labels | |

In addition, your team will have a piece of paper and a pencil to use as you plan and present your PERFORMANCE.

Scoring: You will receive

- 1 point (40 points maximum) for each inch (2.54cm) your vehicle travels in Part Two.
- Up to 20 points for how creatively you use the materials.
- Up to 20 points for the creativity of your PERFORMANCE.
- Up to 20 points for how well your team works together.

For Appraisers only:

1. The set-up consists of the "test area" at least 4ft x 4ft (121.92cm x 121.92cm).
On one side of the test area is a taped line. There is also a table with materials.

TEAM COPY

Destination ImagiNation *Instant Challenge*

Advanced Level

Where Will It Take You?

Challenge: Your TASK is to build and test a vehicle that will travel as far as possible and then to present a PERFORMANCE in which you show where the vehicle will take you.

Time: You will have up to 4 minutes to use your IMAGINATION to build and test your vehicle, as well as plan your skit and up to 2 minutes to test your vehicle for score and to present your PERFORMANCE to the Appraisers.

Setup: In the center of the room is the “test area.” On one side of the test area is a taped line. There is also a table with materials.

- **Part One (4 minutes):** Use the materials on the table to build a vehicle that will travel as far as possible. You may also test your vehicle, as well as plan your skit, in Part One.
- **Part Two (2 minute):** Move your vehicle for score and present a PERFORMANCE in which you show where the vehicle will take you. Your vehicle should start behind the taped line and travel as far as possible without being touched beyond the taped line. Your vehicle may NOT be thrown. Once your vehicle has stopped, you may retrieve it for another try. You may make as many tries as you want during Part Two. The longest trip will receive score.

In addition, your team will have a piece of paper and a pencil to use as you plan and present your PERFORMANCE.

Scoring: You will receive

- A. 1 point (40 points maximum) for each inch (2.54cm) your vehicle travels in Part Two.
- B. Up to 20 points for how creatively you use the materials.
- C. Up to 20 points for the creativity of your PERFORMANCE.
- D. Up to 20 points for how well your team works together.

Where Will It Take You?

Materials: (Tape to Table)

- 2 Cardboard Tubes
- 2 Rubber Bands
- 1 Pencil
- 2 Paper Bags
- 6 Paper Clips
- 2 Plastic Spoons
- 4 Straws
- 1 Piece of Heavy Paper
- 3 Plastic Lids
- 2 Mailing Labels

In addition, your team will have a piece of paper and a pencil to use as you plan and present your PERFORMANCE.

APPRAISER COPY

Destination ImagiNation *Instant Challenge*

Entry and Advanced Levels

FOOT PUPPETS

Challenge: Your **TASK** is to create at least 2 foot puppets and then to present a **PERFORMANCE** using the puppets.

Time: You will have up to 5 minutes to use your IMAGINATION to create your puppets, as well as to plan and practice your puppet show, and then up to 2 minutes to present your PERFORMANCE .

The Scene:

- **Part One (5 minutes):** Use the materials to create at least 2 foot puppets. You should also use Part One to plan and practice your puppet show. You may remove your shoes when performing with your foot puppets.
- **Part Two (2 minutes):** Present your PERFORMANCE.

Materials:

- 8 Pieces of Paper
- 12 Mailing Labels
- 1 Pair of Scissors
- 20 Rubber Bands
- 12 Colored Dots
- 6 Chenille Sticks (Pipe Cleaners)
- 3 ft (91.44cm) of Yarn
- 8 Markers

The markers and scissors may NOT be damaged and may NOT be part of your foot puppets. In addition, a piece of paper and a pencil will be available for your team to use as you plan and present your PERFORMANCE.

Scoring: You will receive up to

- 40 points for the creativity of your foot puppets.
- 40 points for the creativity of your PERFORMANCE.
- 20 points for how well your team works together.

FOOT PUPPETS

For Appraisers only:

1. The set-up consists of a screen held up by 2 ladders on one side of the room. The screen should be 18in (45.72cm) off of the floor. There should be a bench on the far side of the screen, in between the 2 ladders.

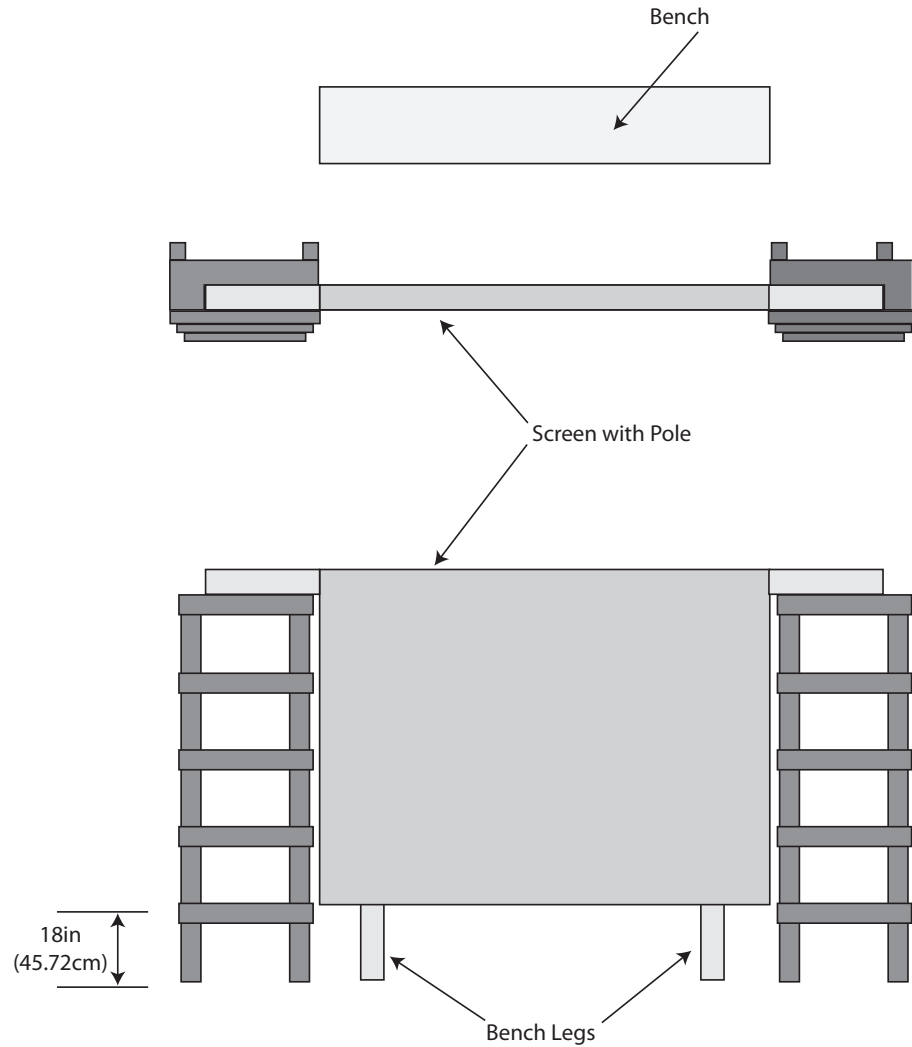

TEAM COPY

Destination ImagiNation *Instant Challenge*

Entry and Advanced Levels

FOOT PUPPETS

Challenge: Your **TASK** is to create at least 2 foot puppets and then to present a **PERFORMANCE** using the puppets.

Time: You will have up to 5 minutes to use your IMAGINATION to create your puppets, as well as to plan and practice your puppet show, and then up to 2 minutes to present your PERFORMANCE .

The Scene:

- **Part One (5 minutes):** Use the materials to create at least 2 foot puppets. You should also use Part One to plan and practice your puppet show. You may remove your shoes when performing with your foot puppets.
- **Part Two (2 minutes):** Present your PERFORMANCE.

Materials:

- | | | |
|---|--|--|
| <input type="checkbox"/> 8 Pieces of Paper | <input type="checkbox"/> 20 Rubber Bands | <input type="checkbox"/> 3ft (91.44cm) of Yarn |
| <input type="checkbox"/> 12 Mailing Labels | <input type="checkbox"/> 12 Colored Dots | <input type="checkbox"/> 8 Markers |
| <input type="checkbox"/> 1 Pair of Scissors | <input type="checkbox"/> 6 Chenille Sticks (Pipe Cleaners) | |

The markers and scissors may NOT be damaged and may NOT be part of your foot puppets. In addition, a piece of paper and a pencil will be available for your team to use as you plan and present your PERFORMANCE.

Scoring: You will receive up to

- 40 points for the creativity of your foot puppets.
- 40 points for the creativity of your PERFORMANCE.
- 20 points for how well your team works together.

FOOT PUPPETS

Materials:

(Tape to Table)

- 8 Pieces of Paper
- 20 Rubber Bands
- 3ft (91.44cm) of Yarn
- 12 Mailing Labels
- 12 Colored Dots
- 8 Markers
- 1 Pair of Scissors
- 6 Chenille Sticks (Pipe Cleaners)

The markers and scissors may NOT be damaged and may NOT be part of your foot puppets. In addition, a piece of paper and a pencil will be available for your team to use as you plan and present your PERFORMANCE.

Create Your Own *Instant Challenges*

Purpose

- To teach teams to create their own *Instant Challenges* from the table below.
- To give teams additional practice in *Instant Challenge*.
- To introduce the Morphological Matrix Creative Problem Solving Tool

Procedure:

1. Gather the materials in Column A (or substitute whatever is handy!).
2. Decide which type of *IC* you would like to create: Performance-Based, Task-Based, or a Combination, then follow the directions below.
3. Appoint two team members to act as Appraisers. Be sure one serves as a Timekeeper.
4. Appoint one or more team members to act as observers. Have them make notes about the rest of the team as they solve the Challenge.
5. Don't forget to DEBRIEF using the 10 questions on page 1!
 - **Performance-Based Challenge:** RANDOMLY choose one or more items from A and one item from D and E
 - **Combination Challenge:** RANDOMLY choose one or more items from A, and one item from one or more of the other columns (you MAY skip Column B, for example, and still have a great *IC*). We encourage you to experiment!
 - **Task-Based Challenge:** RANDOMLY choose one or more items from A and one item from B and C.

	A: MATERIALS	B: MAKE A ...	C: THAT WILL...	D: PLACE	SITUATION
1.	Cardboard box	Communication device	Fly	Middle of a street	Talking to a moose
2.	Tissue paper	Vehicle	Make a job easier	Faraway planet	A day too early!
3.	Plastic shopping bag	Aircraft	Appeal to a toddler	Top of a mountain	Lost a lot of money!
4.	Handful of spaghetti	Protective roof	Make people giggle	Attic	Selling cars
5.	Toilet paper roll	Sculpture	Appeal to a grandparent	Wild, scary jungle	Cleaning house
6.	String	Device	Scare people	Seashore	Discovered a new species of insect
7.	Aluminum foil	Tower	Hold a brick	Amusement park	Doing a lab experiment
8.	Poster board	Shelter	Protect an egg	On top of a pizza	Lost your way
9.	Yard (meter) stick	Piece of jewelry	Make noise	In the clothes dryer	Trying to borrow money
10.	Basket	Yard tool	Hit a target	Mansion	Playing a game with no rules
11.	Clay	Article of clothing	Hold as many nails as possible	Fish aquarium	In a drama
12.	Straws	Container	Move by itself	Dark movie theater	Are very full
13.	Toothpicks	Game	Make people worried	Under the ocean	Trying to dance
14.	Index cards	Crane	Shake	Antarctica	Riding a racehorse

Destination ImagiNation *Instant Challenge*

Challenge:

Your Challenge is to _____

Time:

You will have up to _____ minutes to use your IMAGINATION to _____

Setup:

Procedure:

Scoring: You will receive

- A. _____
- B. _____
- C. _____
- D. _____
- E. Up to 20 points for how well your team works together.